

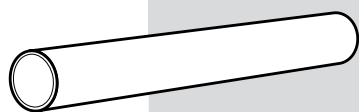

Rohre und Formteile aus PP / Pipes and fittings made of PP

Rohre / Pipe





| | Seite |
|------------------|-------|
| Prod.Gruppen 705 | |
| SDR 7,4 | 92 |
| SDR 11 | 93 |
| SDR 17,6 | 94 |
| SDR 26 | 95 |
| SDR 33 | 96 |
| SDR 41 | 97 |
| Lüftungsreihe | 98 |

Kurze Formteile / Fittings with short spigot

| | |
|---|---|
|  | MULTI-Bögen 90° / MULTI bend 90° Prod.Gruppe 068.....99 |
|---|---|

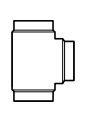
| | |
|--|--|
|  | Bögen 90° / Bend 90° Prod.Gruppe 001.....100 |
|--|--|

| | |
|---|---|
|  | T-Stücke, T-Stücke mit red. Ab- gang / Tee Prod.Gruppe 006.....101 Prod.Gruppe 016.....103 |
|---|---|

| | |
|---|--|
|  | Vorschweißbunde / Stub flange Prod.Gruppe 012.....104 V-Bunde für den Einbau von Ab- sperrklappen siehe im Kapitel „Flansche und Sonderteile“ |
|---|--|

| | |
|---|--|
|  | Losflansche / Backing ring Prod.Gruppe 014.....105 |
|---|--|

| | |
|---|--|
|  | Reduktionen / Reducer Prod.Gruppe 941.....106 Prod.Gruppe 007.....109 |
|---|--|

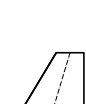
| | |
|---|---|
|  | Reduktionen exzentrisch / Reducer excentric Prod.Gruppe 005.....110 |
|---|---|

| | Seite |
|---|---|
|  | Verschraubungen Typ 24 / Union type 24 Prod.Gruppe 024111 Einschraubteil Typ24111 Einlegteile Typ 24111 Überwurfmutter Typ 24112 |

| | |
|---|--|
|  | Adapter / Adaptor Prod.Gruppe 033112 Prod.Gruppe 032112 |
|---|--|

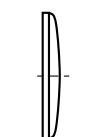
| | |
|---|---|
|  | Endkappe / End cap Prod.Gruppe 004113 |
|---|---|

Lange Formteile / Fittings with long spigot

| | |
|--|--|
|  | MULTI-Bögen 90° / MULTI Bend 90° Prod.Gruppe 068.....114 |
|--|--|

| | |
|---|--|
|  | Bögen 90° / Bend 90° Prod.Gruppe 011.....115 |
|---|--|

| | |
|---|--|
|  | Winkel 90° / Elbow 90° Prod.Gruppe 061.....115 |
|---|--|

| | |
|---|--|
|  | Winkel 45° / Elbow 45° Prod.Gruppe 060.....116 |
|---|--|

| | |
|---|---|
|  | T-Stücke, T-Stücke mit red. Abgang / Tee Prod.Gruppe 066118 Prod.Gruppe 065119 |
|---|---|

| | |
|---|--|
|  | Vorschweißbunde / Stub flange Prod.Gruppe 062121 V-Bunde für den Einbau von Ab- sperrklappen siehe Kapitel „Flansche und Sonderteile“ |
|---|--|

| | |
|---|---|
|  | Losflansche / Backing ring Prod.Gruppe 014122 |
|---|---|

| | |
|---|--|
|  | Reduktionen exzentrisch / Reducer excentric Prod.Gruppe 069123 |
|---|--|

| | |
|---|---|
|  | Reduktionen / Reducer concentric Prod.Gruppe 067124 |
|---|---|

| | |
|---|---|
|  | Endkappen / End cap Prod.Gruppe 0640125 |
|---|---|

Heizwendelformteile / Electrofusion fittings

| | |
|---|---|
|  | Muffen / E-coupler Prod.Gruppe 173126 |
|---|---|

Formteile für Muffenschweißung / Fittings for socket welding

| | |
|---|---|
|  | Winkel 90° / Elbow 90° Prod.Gruppe 051127 |
|---|---|

| | |
|---|---|
|  | Winkel 45° / Elbow 45° Prod.Gruppe 050127 |
|---|---|

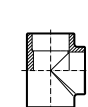
| | |
|---|---|
|  | T-Stücke, T-Stücke mit red. Ab- gang / Tee Prod.Gruppe 056127 Prod.Gruppe 055128 |
|---|---|

| | |
|---|---|
|  | Bundbuchsen / Flange adaptor Prod.Gruppe 052128 |
|---|---|

| | |
|---|--|
|  | Muffen / Socket Prod.Gruppe 053128 |
|---|--|

| | |
|---|--|
|  | Reduktionen / Reducer Prod.Gruppe 057129 |
|---|--|

| | |
|---|--|
|  | Endkappen / End cap Prod.Gruppe 054129 |
|---|--|

| | |
|---|---|
|  | Verschraubungen Typ 24 / Union type 24 Prod.Gruppe 024130 |
|---|---|

Rohre / Pipe

aus PP nach DIN 8077 / 78
in Standardlängen von 5 m

Artikelgruppe

PP-H 100

12 705...

| SDR 7,4 | d | s | d _i | kg/m |
|---------|-----|-------------------|----------------|-------|
| | 10 | 2,0 | 6,4 | |
| | 12 | 2,0 ¹⁾ | 8,0 | 0,06 |
| | 16 | 2,2 | 11,6 | 0,10 |
| | 20 | 2,8 | 14,4 | 0,15 |
| | 25 | 3,5 | 18,0 | 0,23 |
| | 32 | 4,4 | 23,3 | 0,37 |
| | 40 | 5,5 | 29,0 | 0,58 |
| | 50 | 6,9 | 36,2 | 0,90 |
| | 63 | 8,6 | 45,8 | 1,41 |
| | 75 | 10,3 | 54,4 | 2,01 |
| | 90 | 12,3 | 65,4 | 2,87 |
| | 110 | 15,1 | 79,8 | 4,30 |
| | 125 | 17,1 | 90,8 | 5,53 |
| | 140 | 19,2 | 101,6 | 6,95 |
| | 160 | 21,9 | 116,2 | 9,04 |
| | 180 | 24,6 | 130,8 | 11,40 |
| | 200 | 27,4 | 145,2 | 14,10 |
| | 225 | 30,8 | 163,4 | 17,90 |
| | 250 | 34,2 | 181,6 | 22,10 |
| | 280 | 38,3 | 203,4 | 27,60 |
| | 315 | 43,1 | 228,8 | |
| | 355 | 48,5 | 258,0 | |
| | 400 | 54,7 | 290,6 | |
| | 450 | 61,5 | 327,0 | |

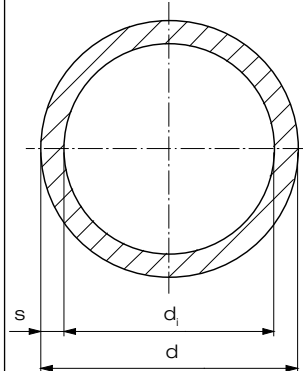

¹⁾ Aus schweißtechnischen Gründen sind die Wanddicken abweichend von der Norm ausgeführt.

| Art.-Nr. | PP-H 100 €/m |
|----------|-----------------|
| - | - |
| - | 1,20 |
| - | - |
| 0020 07 | 1,80 |
| 0025 07 | 2,70 |
| 0032 07 | 4,20 |
| 0040 07 | 5,65 |
| 0050 07 | 8,70 |
| 0063 07 | 13,60 |
| 0075 07 | 19,15 |
| 0090 07 | 27,45 |
| 0110 07 | 41,05 |
| 0125 07 | 52,80 |
| 0140 07 | 66,25 |
| 0160 07 | 86,35 |
| 0180 07 | 100,80 |
| 0200 07 | 124,60 |
| 0225 07 | 175,65 |
| - | - |
| - | - |
| - | - |
| - | - |
| - | - |
| - | - |

Rabattgruppe
PP-H 62

Rohre / Pipe

aus PP nach DIN 8077 / 78
in Standardlängen von 5 m

DIBt
zugelassen

Artikelgruppe **PP-R 100** 11 705...

Artikelgruppe **PP-H 100** 12 705...

| SDR 11 | | d | s | d _i | kg/m |
|--------|--|-----|-------------------|----------------|-------|
| | | 16 | 1,8 ¹⁾ | 12,4 | 0,08 |
| | | 20 | 1,9 | 16,4 | 0,11 |
| | | 25 | 2,3 | 20,4 | 0,16 |
| | | 32 | 2,9 | 26,2 | 0,26 |
| | | 40 | 3,7 | 32,6 | 0,41 |
| | | 50 | 4,6 | 40,8 | 0,64 |
| | | 63 | 5,8 | 51,4 | 1,01 |
| | | 75 | 6,8 | 61,4 | 1,41 |
| | | 90 | 8,2 | 73,6 | 2,03 |
| | | 110 | 10,0 | 90,0 | 3,01 |
| | | 125 | 11,4 | 102,2 | 3,91 |
| | | 140 | 12,7 | 114,6 | 4,87 |
| | | 160 | 14,6 | 130,8 | 6,38 |
| | | 180 | 16,4 | 147,2 | 8,07 |
| | | 200 | 18,2 | 163,6 | 9,95 |
| | | 225 | 20,5 | 184,0 | 11,26 |
| | | 250 | 22,7 | 204,6 | 15,50 |
| | | 280 | 25,4 | 229,2 | 19,40 |
| | | 315 | 28,6 | 257,8 | 24,60 |
| | | 355 | 32,2 | 290,6 | 31,20 |
| | | 400 | 36,3 | 327,4 | 39,60 |
| | | 450 | 40,9 | 368,2 | 50,10 |
| | | 500 | 45,4 | 409,2 | 61,70 |
| | | 560 | 50,8 | 458,4 | |
| | | 630 | 57,2 | 515,6 | |
| | | 710 | 64,5 | 581,0 | |

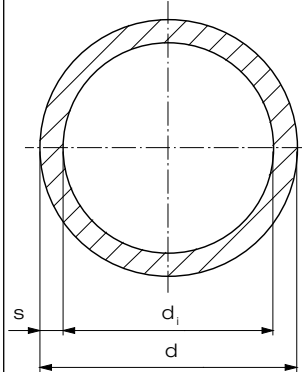

Sonderlängen auf Anfrage

¹⁾ PP = 1,8 mm - aus schweißtechnischen Gründen sind die Wanddicken abweichend von der Norm mit 2 mm ausgeführt.

| Art.-Nr. | PP-H 100 €/m |
|----------|-----------------|
| 0016 11 | 1,45 |
| 0020 11 | 1,50 |
| 0025 11 | 2,00 |
| 0032 11 | 2,75 |
| 0040 11 | 3,60 |
| 0050 11 | 5,55 |
| 0063 11 | 8,75 |
| 0075 11 | 12,15 |
| 0090 11 | 17,40 |
| 0110 11 | 25,85 |
| 0125 11 | 33,40 |
| 0140 11 | 41,80 |
| 0160 11 | 54,75 |
| 0180 11 | 69,05 |
| 0200 11 | 85,05 |
| 0225 11 | 108,05 |
| 0250 11 | 132,85 |
| 0280 11 | 166,20 |
| 0315 11 | 210,80 |
| 0355 11 | 319,60 |
| 0400 11 | 405,90 |
| 0450 11 | 526,05 |
| 0500 11 | 647,85 |
| - | 791,00 |
| - | - |
| - | - |

Rabattgruppe
PP-H 108

Rohre / Pipe

aus PP nach DIN 8077 / 78
in Standardlängen von 5 m

Artikelgruppe

PP-H100

12 705...

DIBt
zugelassen

| SDR 17,6 | d | s | d _i | kg/m |
|----------|------|-------------------|----------------|--------|
| | 20 | 1,8 ¹⁾ | 16,0 | 0,10 |
| | 25 | 2,0 ¹⁾ | 21,0 | 0,13 |
| | 32 | 2,0 ¹⁾ | 28,0 | 0,17 |
| | 40 | 2,3 | 35,4 | 0,27 |
| | 50 | 2,9 | 44,2 | 0,42 |
| | 63 | 3,6 | 55,8 | 0,66 |
| | 75 | 4,3 | 66,4 | 0,94 |
| | 90 | 5,1 | 79,8 | 1,33 |
| | 110 | 6,3 | 97,4 | 1,99 |
| | 125 | 7,1 | 110,8 | 2,55 |
| | 140 | 8,0 | 124,0 | 3,20 |
| | 160 | 9,1 | 141,8 | 4,17 |
| | 180 | 10,2 | 159,6 | 5,25 |
| | 200 | 11,4 | 177,2 | 6,50 |
| | 225 | 12,8 | 199,4 | 8,19 |
| | 250 | 14,2 | 221,6 | 10,10 |
| | 280 | 15,9 | 248,2 | 12,60 |
| | 315 | 17,9 | 279,2 | 16,00 |
| | 355 | 20,1 | 314,8 | 20,30 |
| | 400 | 22,7 | 355,2 | 25,70 |
| | 450 | 25,5 | 399,0 | 32,50 |
| | 500 | 28,3 | 443,4 | 40,20 |
| | 560 | 31,7 | 496,6 | 50,30 |
| | 630 | 35,7 | 558,6 | 63,70 |
| | 710 | 40,2 | 629,6 | 80,80 |
| | 800 | 45,3 | 709,4 | 103,00 |
| | 900 | 51,0 | 798,0 | 130,00 |
| | 1000 | 56,7 | 886,6 | 167,56 |

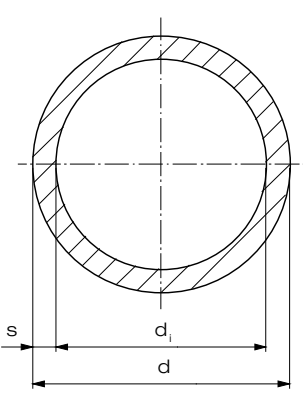

Sonderlängen auf Anfrage

¹⁾ PP = 2,0 mm - aus schweißtechnischen Gründen sind die Wanddicken abweichend von der Norm ausgeführt.

| Art.-Nr. | PP-H 100 €/m |
|----------|-----------------|
| 0020 17 | 1,40 |
| 0025 17 | 1,65 |
| 0032 17 | 2,25 |
| 0040 17 | 3,15 |
| 0050 17 | 3,75 |
| 0063 17 | 5,80 |
| 0075 17 | 8,05 |
| 0090 17 | 11,45 |
| 0110 17 | 17,15 |
| 0125 17 | 21,85 |
| 0140 17 | 27,55 |
| 0160 17 | 35,65 |
| 0180 17 | 44,85 |
| 0200 17 | 55,50 |
| 0225 17 | 70,30 |
| 0250 17 | 86,60 |
| 0280 17 | 108,05 |
| 0315 17 | 137,15 |
| 0355 17 | 207,60 |
| 0400 17 | 257,85 |
| 0450 17 | 324,25 |
| 0500 17 | 400,05 |
| 0560 17 | 501,70 |
| 0630 17 | 635,30 |
| 0710 17 | 804,95 |
| 0800 17 | 1.023,35 |
| - | - |
| - | - |

Rabattgruppe
PP-H 108

Rohre / Pipe

aus PP nach DIN 8077 / 78
in Standardlängen von 5 m

Artikelgruppe

PP-H100

12 705...

| SDR 26 | d | s | d _i | kg/m |
|--------|------|-------------------|----------------|--------|
| | 40 | 2,0 ¹⁾ | 36,0 | 0,22 |
| | 50 | 2,0 | 46,0 | 0,30 |
| | 63 | 2,5 | 58,0 | 0,47 |
| | 75 | 2,9 | 69,2 | 0,65 |
| | 90 | 3,5 | 83,0 | 0,94 |
| | 110 | 4,2 | 101,6 | 1,37 |
| | 125 | 4,8 | 115,4 | 1,76 |
| | 140 | 5,4 | 129,2 | 2,23 |
| | 160 | 6,2 | 147,6 | 2,92 |
| | 180 | 6,9 | 166,2 | 3,63 |
| | 200 | 7,7 | 184,6 | 4,50 |
| | 225 | 8,6 | 207,8 | 5,65 |
| | 250 | 9,6 | 230,8 | 6,99 |
| | 280 | 10,7 | 258,6 | 8,72 |
| | 315 | 12,1 | 290,8 | 11,10 |
| | 355 | 13,6 | 327,8 | 14,00 |
| | 400 | 15,3 | 369,4 | 17,80 |
| | 450 | 17,2 | 415,6 | 22,50 |
| | 500 | 19,1 | 461,8 | 27,70 |
| | 560 | 21,4 | 517,2 | 34,70 |
| | 630 | 24,1 | 581,8 | 44,00 |
| | 710 | 27,2 | 655,6 | 55,90 |
| | 800 | 30,6 | 738,8 | 70,80 |
| | 900 | 34,4 | 831,2 | 89,50 |
| | 1000 | 38,2 | 923,6 | 110,00 |
| | 1200 | 45,9 | 1108,2 | 159,00 |
| | 1400 | 53,5 | 1293,0 | 216,00 |

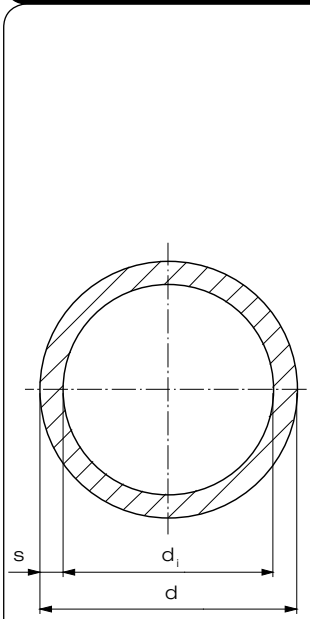

Sonderlängen auf Anfrage

¹⁾ Aus schweißtechnischen Gründen sind die Wanddicken abweichend von der Norm ausgeführt.

| Art.-Nr. | PP-H 100 €/m. |
|----------|------------------|
| 0040 26 | 2,20 |
| 0050 26 | 3,00 |
| 0063 26 | 4,60 |
| 0075 26 | 6,30 |
| 0090 26 | 9,05 |
| 0110 26 | 13,10 |
| 0125 26 | 16,85 |
| 0140 26 | 21,25 |
| 0160 26 | 27,70 |
| 0180 26 | 34,75 |
| 0200 26 | 43,00 |
| 0225 26 | 53,95 |
| 0250 26 | 66,80 |
| 0280 26 | 83,30 |
| 0315 26 | 106,05 |
| 0355 26 | 133,65 |
| 0400 26 | 168,95 |
| 0450 26 | 229,40 |
| 0500 26 | 282,60 |
| 0560 26 | 363,40 |
| 0630 26 | 518,60 |
| 0710 26 | 659,10 |
| 0800 26 | 836,30 |
| 0900 26 | 1.057,25 |
| 1000 26 | 1.300,80 |
| 1200 26 | auf Anfrage |
| 1400 26 | auf Anfrage |

Rabattgruppe
PP-H 62

Rohre / Pipe

aus PP nach DIN 8077 / 78
in Standardlängen von 5 m

Artikelgruppe

PP-H100

12 705...

| SDR 33 | d | s | d _i | kg/m |
|--------|------|-------------------|----------------|--------|
| | 50 | 2,0 ¹⁾ | 46,0 | 0,27 |
| | 63 | 2,0 | 59,0 | 0,38 |
| | 75 | 2,3 | 70,4 | 0,53 |
| | 90 | 2,8 | 84,4 | 0,76 |
| | 110 | 3,4 | 103,0 | 1,12 |
| | 125 | 3,9 | 117,2 | 1,45 |
| | 140 | 4,3 | 131,4 | 1,80 |
| | 160 | 4,9 | 150,2 | 2,32 |
| | 180 | 5,5 | 169,0 | 2,94 |
| | 200 | 6,2 | 187,6 | 3,68 |
| | 225 | 6,9 | 211,2 | 4,57 |
| | 250 | 7,7 | 234,6 | 5,67 |
| | 280 | 8,6 | 262,8 | 7,09 |
| | 315 | 9,7 | 295,6 | 8,97 |
| | 355 | 10,9 | 332,8 | 11,30 |
| | 400 | 12,3 | 375,4 | 14,40 |
| | 450 | 13,8 | 422,4 | 18,20 |
| | 500 | 15,3 | 469,4 | 22,40 |
| | 560 | 17,2 | 525,6 | 28,20 |
| | 630 | 19,3 | 591,4 | 35,60 |
| | 710 | 21,8 | 666,4 | 45,20 |
| | 800 | 24,5 | 751,0 | 57,20 |
| | 900 | 27,6 | 844,8 | 72,50 |
| | 1000 | 30,6 | 938,8 | 89,20 |
| | 1200 | 36,7 | 1126,6 | 128,00 |
| | 1400 | 42,9 | 1314,2 | 175,00 |

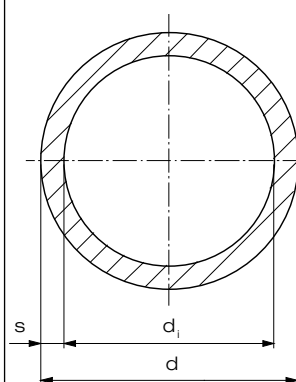

Sonderlängen auf Anfrage

¹⁾ Aus schweißtechnischen Gründen sind die Wanddicken abweichend von der Norm ausgeführt.

| PP Art.-Nr. | PP-H 100 €/m |
|----------------|-----------------|
| 0050 33 | 3,00 |
| 0063 33 | 3,75 |
| 0075 33 | 5,05 |
| 0090 33 | 7,30 |
| 0110 33 | 10,70 |
| 0125 33 | 13,95 |
| 0140 33 | 17,10 |
| 0160 33 | 22,30 |
| 0180 33 | 28,15 |
| 0200 33 | 34,90 |
| 0225 33 | 43,70 |
| 0250 33 | 54,20 |
| 0280 33 | 67,75 |
| 0315 33 | 85,65 |
| 0355 33 | 107,85 |
| 0400 33 | 137,50 |
| 0450 33 | 186,40 |
| 0500 33 | 234,15 |
| 0560 33 | 295,10 |
| 0630 33 | 410,05 |
| 0710 33 | 522,05 |
| 0800 33 | 660,65 |
| 0900 33 | 857,40 |
| 1000 33 | 1.054,90 |
| 1200 33 | 1.575,30 |
| 1400 33 | 2.153,70 |

Rabattgruppe
PP-H 62

Rohre / Pipe

aus PP nach DIN 8077 / 78
in Standardlängen von 5 m

Artikelgruppe

PP-H 100

12 705...

PP

| SDR 41 | | | | |
|--------|------|-------------------|----------------|--------|
| | d | s | d _i | kg/m |
| | 63 | 1,8 ¹⁾ | 59,4 | 0,35 |
| | 75 | 1,9 ¹⁾ | 71,2 | 0,44 |
| | 90 | 2,2 | 85,6 | 0,62 |
| | 110 | 2,7 | 104,6 | 0,90 |
| | 125 | 3,1 | 118,8 | 1,18 |
| | 140 | 3,5 | 133,0 | 1,48 |
| | 160 | 4,0 | 152,2 | 1,91 |
| | 180 | 4,4 | 171,2 | 2,38 |
| | 200 | 4,9 | 190,2 | 2,92 |
| | 225 | 5,5 | 214,0 | 3,70 |
| | 250 | 6,2 | 237,6 | 4,63 |
| | 280 | 6,9 | 266,2 | 5,73 |
| | 315 | 7,7 | 299,6 | 7,20 |
| | 355 | 8,7 | 337,6 | 9,14 |
| | 400 | 9,8 | 380,4 | 11,60 |
| | 450 | 11,0 | 428,0 | 14,70 |
| | 500 | 12,3 | 475,4 | 18,20 |
| | 560 | 13,7 | 532,6 | 22,60 |
| | 630 | 15,4 | 599,2 | 28,60 |
| | 710 | 17,4 | 675,2 | 36,40 |
| | 800 | 19,6 | 760,8 | 46,10 |
| | 900 | 22,0 | 856,0 | 58,30 |
| | 1000 | 24,5 | 951,0 | 72,00 |
| | 1200 | 29,4 | 1141,2 | 104,00 |
| | 1400 | 34,3 | 1331,4 | 141,00 |

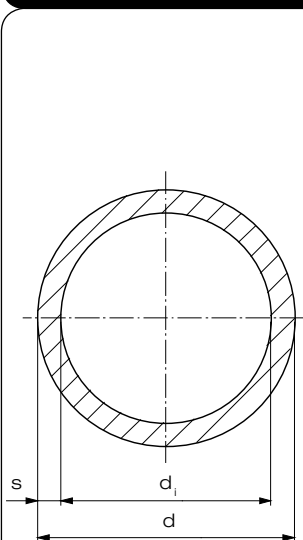

Sonderlängen auf Anfrage

¹⁾ Aus schweißtechnischen Gründen sind die Wanddicken abweichend von der Norm ausgeführt.

| PP Art.-Nr. | PP-H 100 €/m |
|----------------|-----------------|
| 0063 41 | 3,65 |
| 0075 41 | 4,55 |
| 0090 41 | 6,15 |
| 0110 41 | 9,10 |
| 0125 41 | 11,85 |
| 0140 41 | 15,00 |
| 0160 41 | 19,25 |
| 0180 41 | 23,80 |
| 0200 41 | 29,35 |
| 0225 41 | 37,25 |
| 0250 41 | 46,15 |
| 0280 41 | 57,65 |
| 0315 41 | 72,20 |
| 0355 41 | 91,80 |
| 0400 41 | 116,50 |
| 0450 41 | 157,25 |
| 0500 41 | 195,95 |
| 0560 41 | 243,30 |
| 0630 41 | 329,25 |
| 0710 41 | 419,30 |
| 0800 41 | 532,45 |
| 0900 41 | 713,20 |
| 0100 41 | 883,75 |
| 0121 41 | 1.328,05 |
| 0141 41 | 1.817,95 |

Rabattgruppe
PP-H 62

P VDF / ECTFE

Sonderwerkstoffe

PURAD

Flansche und Sonderteile

Armaturen

Doppelrohr

Halbzeuge / Wickelrohr

Geothermie

Betonschutzplatten

Schweißtechnik

Geobaustoffe

Rohre / Pipe

aus PP
in Längen von 5 m

Artikelgruppe **PP-H100** 12 705...

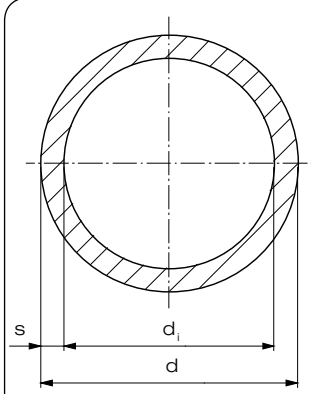
| Lüftungsreihe | d | s | d _i | kg/m |
|---|------|------|----------------|-------|
|  | 200 | 3,0 | 194 | 1,83 |
| | 250 | 3,5 | 243 | 2,66 |
| | 315 | 5,0 | 305 | 4,74 |
| | 355 | 6,0 | 343 | 6,39 |
| | 400 | 6,0 | 388 | 7,20 |
| | 400 | 8,0 | 384 | - |
| | 450 | 6,0 | 438 | 8,10 |
| | 450 | 8,0 | 434 | 8,12 |
| | 500 | 8,0 | 484 | 11,90 |
| | 560 | 8,0 | 540 | 13,41 |
| | 630 | 10,0 | 610 | 18,80 |
| | 710 | 12,0 | 686 | 25,30 |
| | 800 | 12,0 | 776 | 28,60 |
| | 900 | 15,0 | 870 | 40,10 |
| | 1000 | 15,0 | 970 | 44,60 |
| | 1200 | 18,0 | 1164 | 64,10 |
| | 1400 | 20,0 | 1360 | 83,20 |

Sonderlängen auf Anfrage

| €/m | PP-H 100 €/m |
|---------|-----------------|
| 0200 00 | 20,20 |
| 0250 00 | 29,35 |
| 0315 00 | 52,30 |
| 0355 00 | 59,00 |
| 0400 00 | 79,50 |
| 0400 00 | |
| 0450 00 | 95,10 |
| 0450 00 | |
| 0500 00 | 139,60 |
| 0560 00 | 194,60 |
| 0630 00 | 220,40 |
| 0710 00 | 296,60 |
| 0800 00 | 335,20 |
| 0900 00 | 502,20 |
| 1000 00 | 558,50 |
| 1200 00 | 850,70 |
| 1400 00 | 1.104,15 |

Rabattgruppe
PP-H 71